

SIEMENS



SITRANS F

Vortex flowmeters

SITRANS FX300

Supplementary instructions

Edition

05/2015

Answers for industry.

| | | |
|----------|--|-----------|
| 1 | Safety instructions | 3 |
| <hr/> | | |
| 1.1 | General notes | 3 |
| 1.2 | EC conformity | 3 |
| 1.3 | Approval according to the IECEx scheme | 3 |
| 1.4 | Safety instructions..... | 3 |
| 2 | Device description | 4 |
| <hr/> | | |
| 2.1 | Device description | 4 |
| 2.2 | Description code | 4 |
| 2.3 | Marking | 5 |
| 2.4 | Flammable products | 6 |
| 2.5 | Equipment category | 6 |
| 2.6 | Types of protection | 7 |
| 2.7 | Ambient temperature / temperature classes..... | 7 |
| 2.8 | Electrical data..... | 10 |
| 3 | Installation | 11 |
| <hr/> | | |
| 3.1 | Installation | 11 |
| 3.2 | Special Conditions | 12 |
| 4 | Electrical connections | 13 |
| <hr/> | | |
| 4.1 | General notes | 13 |
| 4.2 | Power supply | 13 |
| 4.3 | Inputs / outputs | 13 |
| 4.4 | Earthing and equipotential bonding | 14 |
| 4.5 | Sensor circuits (remote version only) | 15 |
| 5 | Operation | 16 |
| <hr/> | | |
| 5.1 | Start-up..... | 16 |
| 5.2 | Operation | 16 |
| 6 | Service | 17 |
| <hr/> | | |
| 6.1 | Maintenance | 17 |
| 6.2 | Dismantling | 17 |
| 7 | Notes | 19 |
| <hr/> | | |

1.1 General notes

These additional "Ex" instructions apply to explosion-protected versions of vortex flowmeters with the marking II 2 G. They complement the standard documentation for the non-explosion protected versions.

The information given in these Instructions contains only the data relevant to Category 2 explosion protection. The technical details given in the standard documentation for the non-explosion protected versions apply unchanged unless excluded or superseded by these Instructions.

1.2 EC conformity

The manufacturer declares with the EC Declaration of Conformity on his own responsibility conformity with the protection goals of Directive 94/9/EC for use in hazardous areas with gas.

The EC Type Examination Certificate of the Physikalisch Technische Bundesanstalt (PTB) forms the basis of the EC Declaration of Conformity:

PTB 08 ATEX 2022 X

The "X" after the certificate number refers to special conditions for safe use of the device, which have been listed in these Instructions.

The EC Type Examination Certificate may be downloaded from the manufacturer's website as needed.

1.3 Approval according to the IECEx scheme

Conformity with IECEx standards was tested in accordance with the IECEx Certification Scheme for Explosive Atmospheres acc. to IEC 60079-0 and IEC 60079-11. The number of the IEC certificate is:

IECEx PTB 12.0019X

1.4 Safety instructions

Assembly, installation, start-up and maintenance may only be performed by personnel trained in explosion protection!



CAUTION!

Should operating conditions and locations require the observance of further standards, guidelines and laws, this is the responsibility of the operator and/or those commissioned by him.

2.1 Device description

Vortex flowmeters measure and display the volume flow of flammable and non-flammable gases and liquids.. The display unit contains a 4...20 mA signal output with optional HART[®] communication and a separate pulse/status output.

2.2 Description code

The safety description code * consists of the following elements:

SITRANS FX300 . / ...

① ② ③ ④

- ① SITRANS vortex flowmeter
- ② Type series FX300
- ③ System components
not connected: compact device
C: Converter remote system
S: Sensor remote system
- ④ Marking without influence on the explosion safety protection

* positions which are not needed are omitted (no blank positions)

The remote version consisting of the SITRANS FX300 S measuring sensor and the SITRANS FX300 C signal converter is called the SITRANS FX300 R.

2.3 Marking

The marking key is used to mark the devices using the nameplates as illustrated here. On both the compact devices and the remote versions, the main plate is located on the converter housing. On the remote versions there is an additional marking on the sensor.

Compact devices with two converters for dual measurement (Dual Version) are each marked with a nameplate, which is affixed to each of the converter housings. The details relevant to explosion protection are identical on both nameplates.

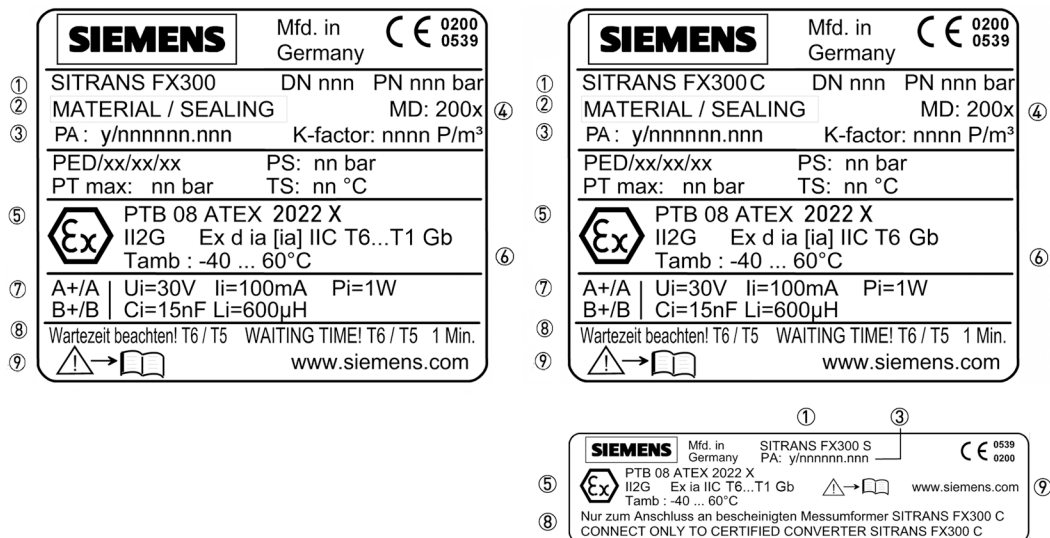

- ① Device version
- ② Materials sensor and sealing
- ③ Serial number
- ④ Year of manufacture
- ⑤ Marking as per PTB 08 ATEX 2022X or IECEx PTB 12.0019X
- ⑥ Permissible ambient temperature range
- ⑦ Maximum values intrinsically safe circuits
- ⑧ Safety instructions
- ⑨ Observe operating instructions

2.4 Flammable products

Atmospheric conditions

An explosive atmosphere is defined as a mixture of air and flammable gases, vapours, mists or dusts under atmospheric conditions with the values

$T_{\text{atm}} = -20\dots+60^{\circ}\text{C} / -4\dots+140^{\circ}\text{F}$ and $P_{\text{atm}} = 0.8\dots1.1$ bar.

Outside of this range, no key data are available as to ignition behaviour for most mixtures.

Operating conditions

Vortex flowmeters operate outside of atmospheric conditions, which means that explosion protection according to Directive 94/9/EC (ATEX) – regardless of the zone assignment – is fundamentally not applicable due to the lack of key safety data for the interior of the measuring unit.



WARNING!

Operation with flammable products is only permitted as long as no explosive fuel/air mixture builds up on the inside of the flowmeter under operating conditions. The operator is responsible for ensuring that the flowmeter is operated safely as regards the temperature and pressure of the products used.

In case of operation with flammable products the measuring units must be included in the periodic pressure tests of the system.

2.5 Equipment category

Vortex flowmeters are designed according to EN 60079-0, EN 60079-1 and EN 60079-11 in category II 2 G for use in zone 1. The inside of the measuring unit is also approved for zone 1.



INFORMATION!

Definition of zone 1 as per EN 1127-1, Annex B:

An area in which an explosive atmosphere may occasionally occur as a result of the mixture of flammable substances in the form of gas, steam or mist with air under normal operation.

For more information see the chapter entitled "Flammable products".

2.6 Types of protection

| | |
|--|-----------------------------------|
| The marking on the compact device as per ATEX is: | II 2G Ex d ia [ia] IIC T6...T1 Gb |
| The marking on the remote converter as per ATEX is: | II 2G Ex d ia [ia] IIC T6 Gb |
| The marking on the remote sensor as per ATEX is: | II 2G Ex ia IIC T6...T1 Gb |
| The marking on the compact device as per IECEx is: | Ex d ia [ia] IIC T6 Gb |
| The marking on the remote converter as per IECEx is: | Ex d ia [ia] IIC T6 Gb |
| The marking on the remote sensor as per IECEx is: | Ex ia IIC T6 Gb |

The following types of protection are used:

- Electronics compartment - type of protection flameproof enclosure "d"
- Terminal compartment - type of protection intrinsic safety "i"
- Input/output circuits in type of protection intrinsic safety, level of protection "ia" operation on intrinsically safe circuits level of protection "ib" permitted.
- Sensor circuits remote version (compact device only internally) in type of protection intrinsic safety, level of protection "ia"

2.7 Ambient temperature / temperature classes

The permissible range of ambient temperatures for vortex flowmeters is noted on the nameplate and is

$T_{amb} = -40^{\circ}\text{C} \dots +60^{\circ}\text{C} / -40^{\circ}\text{F} \dots +140^{\circ}\text{F}$ and

$T_{amb} = -25^{\circ}\text{C} \dots +60^{\circ}\text{C} / -13^{\circ}\text{F} \dots +140^{\circ}\text{F}$ (until year of manufacture 2008).

Because of the influence of the temperature of the product, no fixed temperature class is assigned to vortex flowmeters. In fact, the temperature class of a device is a function of the temperature of both the product and the environment, as well as the size of the measuring units. The classification for the respective version is outlined in the following tables.

Regardless of the temperature class, the lower limit value for the product temperature is $T_M = -40^{\circ}\text{C} / -40^{\circ}\text{F}$ for all versions.



INFORMATION!

The maximum permissible product temperatures listed in the tables are valid under the following conditions:

- *The measuring device is installed and operated in accordance with the installation instructions in the standard documentation.*
- *It must be ensured that the flowmeter is not heated by the effects of additional heat radiation (sunshine, neighbouring system components) and thus operated above the permissible ambient temperature range.*
- *Insulation must be limited to the piping. Unobstructed ventilation of the indicator part must be ensured.*

Permissible product and ambient temperatures with converter or connection box sensor installed above the measuring section

As shown in the figure below, the measuring device should be installed so that it is protected from direct sunlight.

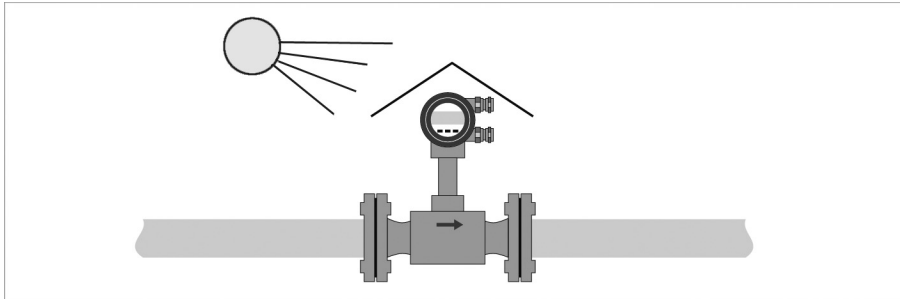

Maximum permissible product and ambient temperatures per temperature class in °C

| Temperature class | T6 | T5 | T4 | | T3 | | | T2 ... T1 | | |
|------------------------|----|----|-----|-----|-----|-------|-------|-----------|-------|-------|
| T _{amb} in °C | 60 | 60 | 50 | 60 | 40 | 50 | 60 | 40 | 50 | 60 |
| Nominal size | | | | | | | | | | |
| DN15 ... 25 | 60 | 75 | 110 | 110 | 175 | 175 ① | 125 ① | 235 ① | 180 ① | 125 ① |
| DN40 ... 50 | 60 | 75 | 110 | 110 | 175 | 165 | 115 | 215 | 165 | 115 |
| DN65 ... 100 | 60 | 75 | 110 | 110 | 175 | 155 | 110 | 200 | 155 | 110 |
| DN150 ... 300 | 60 | 75 | 110 | 110 | 175 | 175 | 130 ① | 240 ① | 190 ① | 130 ① |

① Permanent service temperature of connecting cable and cable entry min. 80°C

Maximum permissible product and ambient temperatures per temperature class in °F

| Temperature class | T6 | T5 | T4 | | T3 | | | T2 ... T1 | | |
|------------------------|-----|-----|-----|-----|-----|-------|-------|-----------|-------|-------|
| T _{amb} in °F | 140 | 140 | 122 | 140 | 104 | 122 | 140 | 104 | 122 | 140 |
| Nominal size | | | | | | | | | | |
| DN15 ... 25 | 140 | 167 | 230 | 230 | 347 | 347 ① | 257 ① | 455 ① | 356 ① | 257 ① |
| DN40 ... 50 | 140 | 167 | 230 | 230 | 347 | 329 | 239 | 419 | 329 | 239 |
| DN65 ... 100 | 140 | 167 | 230 | 230 | 347 | 311 | 230 | 392 | 311 | 230 |
| DN150 ... 300 | 140 | 167 | 230 | 230 | 347 | 347 | 266 ① | 464 ① | 374 ① | 266 ① |

① Permanent service temperature of connecting cable and cable entry min. 176°F

Permissible product and ambient temperatures with converter / connection box sensor installed laterally or below the measuring section

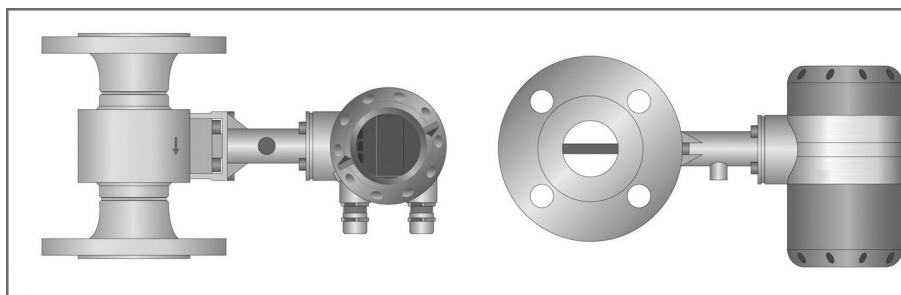

Maximum permissible product and ambient temperatures per temperature class in °C

| Temperature class | T6 | T5 | T4 | | T3 | | | T2 ... T1 | | |
|---------------------|----|----|-----|-----|-----|-------|-------|-----------|-------|-------|
| T_{amb} in °C | 60 | 60 | 50 | 60 | 40 | 50 | 60 | 40 | 50 | 60 |
| Nominal size | | | | | | | | | | |
| DN15 ... 25 | 60 | 75 | 110 | 110 | 175 | 175 ① | 145 ① | 240 ① | 205 ① | 145 ① |
| DN40 ... 50 | 60 | 75 | 110 | 110 | 175 | 175 ① | 135 ① | 240 ① | 205 ① | 135 ① |
| DN65 ... 100 | 60 | 75 | 110 | 110 | 175 | 175 ① | 130 ① | 240 ① | 195 ① | 130 ① |
| DN150 ... 300 | 60 | 75 | 110 | 110 | 175 | 175 ① | 150 ① | 240 ① | 235 ① | 150 ① |

① Permanent service temperature of connecting cable and cable entry min. 80°C

Maximum permissible product and ambient temperatures for temperature class in °F

| Temperature class | T6 | T5 | T4 | | T3 | | | T2 ... T1 | | |
|---------------------|-----|-----|-----|-----|-----|-------|-------|-----------|-------|-------|
| T_{amb} in °F | 140 | 140 | 122 | 140 | 104 | 122 | 140 | 104 | 122 | 140 |
| Nominal size | | | | | | | | | | |
| DN15 ... 25 | 140 | 167 | 230 | 230 | 347 | 347 ① | 293 ① | 464 ① | 401 ① | 293 ① |
| DN40 ... 50 | 140 | 167 | 230 | 230 | 347 | 347 ① | 275 ① | 464 ① | 401 ① | 275 ① |
| DN65 ... 100 | 140 | 167 | 230 | 230 | 347 | 347 ① | 266 ① | 464 ① | 383 ① | 266 ① |
| DN150 ... 300 | 140 | 167 | 230 | 230 | 347 | 347 ① | 302 ① | 464 ① | 455 ① | 302 ① |

① Continuous operating temperature of the connecting cable and cable entry min. 176°F

Maximum permissible product and ambient temperatures for devices with painted measuring sections (all sizes)

| Temp. Class | T6 | | T5 | | T4 ... T1 | |
|--------------|------|-------|------|-------|-----------|-------|
| T_{amb} in | 60°C | 140°F | 60°C | 140°F | 60°C | 140°F |
| T_M | 60°C | 140°F | 75°C | 167°F | 90°C | 194°F |

2.8 Electrical data

Signal circuits

The vortex flowmeter signal circuits may only be connected to separate, intrinsically safe circuits. The maximum permissible values considered safe are listed below. The connection may only be made using separately certified intrinsically safe isolating amplifiers or zener barriers with the following maximum values per circuit:

- $U_i = 30 \text{ V}$
- $I_i = 100 \text{ mA}$
- $P_i = 1,0 \text{ W}$

The following values are to be observed for each intrinsically safe circuit in case of interconnection:

- $C_i = 15 \text{ nF}$
- $L_i \approx 600 \text{ } \mu\text{H}$

Sensor circuits

With the compact device, the intrinsically safe sensor circuits are designed as internal circuits.

When it comes to the remote versions, the intrinsically safe sensor circuits are led through. The maximum permissible values of the sensor circuits considered safe are listed below:

Piezo / Pt1000 circuit

- $U_o = 30 \text{ V}$
- $I_o = 62 \text{ mA}$
- $P_o = 340 \text{ mW}$
- $C_o = 22 \text{ nF}$
- $L_o = 0,35 \text{ mH}$

Pressure transmitter circuit

- $U_o = 30 \text{ V}$
- $I_o = 100 \text{ mA}$
- $P_o = 509 \text{ mW}$
- $C_o = 44 \text{ nF}$
- $L_o = 0,4 \text{ mH}$

3.1 Installation

Installation and setup must be carried out according to the applicable installation standards (e.g. EN 60079-14) by qualified personnel trained in explosion protection. The information given in the manuals and the supplementary instructions must be observed at all times.

Vortex flowmeters must be installed in such a way that

- There are no external forces affecting the indicator part.
- The device is accessible for any visual inspections that are necessary, and can be viewed from all sides.
- The nameplate is clearly visible.
- It can be operated from a location with secure footing.



CAUTION!

The manufacturer is not liable for any damage resulting from improper use or use for other than the intended purpose. This applies in particular to hazards due to insufficient corrosion resistance and suitability of the materials in contact with product.

Converter alignment

The converter may be aligned on the base in 90° increments up to a maximum of $\pm 180^\circ$.

For this reason, the four M6 hexagon socket screws connecting the base and the converter must be loosened. Once the converter has been turned, it must be screwed back on to the base again (tightening torque 6 Nm).

- De-energise the converter.
- Loosen the 4 hexagon socket screws.
- Turn the converter.
- Screw base to converter once again.

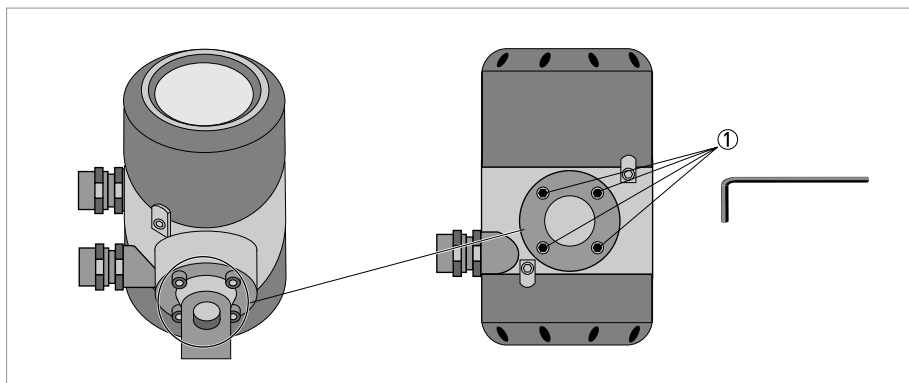

① Screws used to assemble base and converter

3.2 Special Conditions

Equipotential bonding

Vortex flowmeter converters must be included in the equipotential bonding of the hazardous area.

Electronics compartment lock

The vortex flowmeter's flameproof electronics compartment must be closed during operation. The cover of the electronics compartment is secured by a lock. An SW3 hexagon socket screw is used for the safety screw. With temperature classes T6 and T5, a waiting time of 1 minute must be observed prior to opening. For temperature classes T4...T1 the waiting time is not needed.



INFORMATION!

Lock on terminal compartment

The terminal compartment may be opened in hazardous areas when measuring and carrying out adjustments.

4.1 General notes

The separate intrinsically safe signal circuits are electrically connected in the terminal compartment of the converter. The separate intrinsically safe sensor circuits are connected in the terminal compartments on the wall bracket and sensors. The circuits are designed in type of protection "Intrinsic safety".

The connecting cables for signal circuits must be selected and connected according to prevailing installation standards (e.g. EN 60079-14). Ensure that no residual current can form between separate intrinsically safe signal circuits. The connecting cable for the sensor is included in delivery.

- The connecting cables must be fixed and laid so they are sufficiently protected against damage.
- Lay cables so as to ensure that there is sufficient distance between surfaces of the measuring unit and the connecting cable.
- The outer diameter of the connecting cable must be within the sealing range of the cable entry (10...14 mm / 0.4...0.55").
- Unused cable entries are to be closed (>IP67).

Ensure that the seals and cut seals are tight.

4.2 Power supply

Vortex flowmeters do not require a separate power supply. The required supply is provided via the 4...20 mA current output.

4.3 Inputs / outputs

When connecting the vortex flowmeters, observe the following points:

- Before connecting or loosening the equipotential bonding cable, ensure there are no differences in potential.
- All cores and shields belonging to the connecting cables that are not securely fitted to the equipotential bonding of the hazardous area are to be carefully isolated from each other and from ground (test voltage 500 V_{eff}).
- Any existing cable shields should be connected to earth according to applicable installation standards (EN 60079-14). A terminal connection in the terminal compartment permits a short way earthing of the cable shields.
- Only certified intrinsically safe equipment may be connected to the intrinsically safe signal outputs, taking into account the maximum permissible values. The signal outputs must be connected to separate, intrinsically safe circuits.

The current output and the pulse / status output is designed for connection to a certified, intrinsically safe circuit, protection type: intrinsic safety Ex ia IIC or Ex ib IIC.

The current output is safely separated from the pulse / status output up to a peak value of 60V rated voltage. Both circuits are galvanically isolated from the earth.

4.4 Earthing and equipotential bonding



CAUTION!

Equipotential bonding

Vortex flowmeter converters must be included in on-site equipotential bonding as per EN60079-14! They are connected to the PA terminals.

For compact measuring devices and measuring sections with flange connections, the connection may be made via a conducting connection of the sensor to the pipe. For compact measuring devices and "sandwich" type measuring sections, a separate wire must be provided to connect to the equipotential bonding. This wire is connected to the outer PA terminal.

Remote systems can either be included in the equipotential bonding via the PA connection in the converter's terminal compartment or via the external PA connection on the wall bracket.

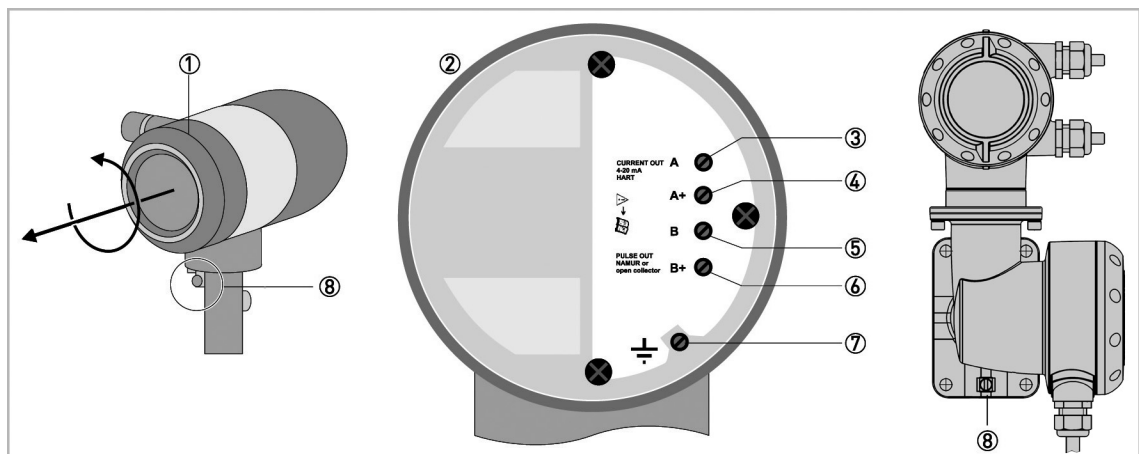

- ① Terminal compartment closed
- ② Terminal compartment open
- ③ Connection A: Current output 4...20 mA (-)
- ④ Connection A+: Current output 4...20 mA (+)
- ⑤ Connection B: pulse / status output (-)
- ⑥ Connection B+: pulse / status output (+)
- ⑦ PA connection interior
- ⑧ PA connection exterior

4.5 Sensor circuits (remote version only)

Observe the following points when connecting the sensor to the converter:

- Use only the supplied connecting cable (max. length 30 m / 98 ft).
- Before connecting or loosening the equipotential bonding cable, ensure there are no differences in potential.
- Connect the connecting cable shield to the equipotential bonding of the hazardous area using the stress resisting clamp in the wall bracket. Sensor-side, the shield must be carefully isolated from the earth (Test voltage 500 V_{eff}).
- The intrinsically safe pressure transmitter circuit (pressure, terminals 1-5) and the intrinsically safe piezo / Pt1000 circuit (piezo, terminals 1-3 and Pt1000, terminals 1-2) are to be galvanically isolated from one another and from the earth along the complete length up to the connections in the wall bracket.

The separate sensor circuits are designed in type of protection intrinsic safety Ex ia IIC.

5.1 Start-up

Start-up may only commence when the vortex flowmeter:

- is correctly installed in the system and connected.
- has been checked for the proper state with regard to its installation and connection requirements.
- and the electronics compartment have been properly closed (flameproof enclosure) and the applicable special lock has been fitted.

The user of the system must have it checked before start-up in compliance with the national regulations for checks before startup.

If the device needs to be configured due to the existence of an explosive atmosphere, this can be done using the supplied programming magnets. There is no need to open the housing as it can be done through the glass window of the electronics compartment or digitally via the signal output (HART[®] interface).

5.2 Operation

Vortex flowmeters must be operated in such a way that they remain within the maximum and minimum permissible temperatures and pressures and the electrical limit values.

Vortex flowmeters may only be operated if the equipment parts necessary for safety are effective in the long run, and are not rendered inoperable during operation.

When it comes to flammable products, the measuring sections must be included in the periodic pressure tests of the system.

Opening the housing of the electronics compartment (type of protection: flameproof enclosure) in hazardous areas is only permitted in a de-energised state and after complying with the waiting time. The waiting time (1 minute) only applies to temperature classes T6 and T5.

Terminal compartments (type of protection: Intrinsic safety) may be opened even in an energised state in hazardous area. Work on electrical connections (e.g. configuration via the HART[®] interface) is also permitted in an energised state. Terminal compartments must be closed immediately upon completion of the work.

6.1 Maintenance

Maintenance work of a safety-relevant nature within the meaning of explosion protection may only be carried out by the manufacturer, his authorised representative or under the supervision of authorised inspectors.

For systems in hazardous areas, regular tests are required in order to maintain the proper condition.

The following checks are recommended:

- Checking the housing, the conduit entry/entries and the feed lines for corrosion and/or damage.
- Checking the measuring section and the piping connections for leaks.
- Checking the measuring section and the indicator for dust deposits.

6.2 Dismantling



CAUTION!

If it is absolutely necessary to open the flameproof enclosure of the electronics compartment in the presence of a potentially explosive atmosphere, the device must be de-energised. Strictly observe the 1 minute waiting time prior to opening the flameproof enclosure. This is indicated on the nameplate of the converter for temperature classes T6 and T5. The waiting period is not necessary for any of the other temperature classes.

General notes

The cover must be opened using a suitable tool (e.g. strap wrench) to avoid damage to the cover. Any replacement or dismantling should take place in a de-energized state if possible. If that is not possible, the basic conditions for intrinsic safety (e.g. no grounding or connection of different intrinsically safe circuits to one another) must be observed during dismantling.

After opening the converter, grease the flameproof threaded joints of the converter's cover including the cover seals if necessary. Use the multi-purpose grease NONTRIBOS[®], type Li EP2.

Display

The display can be freely rotated in 90° increments. It is connected to the connector pictured on the next page. The device should be de-energised before opening the flameproof enclosure. Observe warning without fail.

Exchanging the device insert

It is permitted to replace a complete device insert VFC070 / SITRANS FX300 with a version constructed in the same way.

Take special note of the following figure and:

- ensure that the construction is the same by checking the nameplates.
- the connecting cable of the sensor circuits is to be laid in the cutout provided on the printed circuit board. Avoid damage such as that caused by crushing.
- proper connection of the sensor ③ and the display connector ①
- tighten the mounting screws M4 ⑤ evenly

The device shall be de-energised before opening the flameproof enclosure. Observe warning without fail.

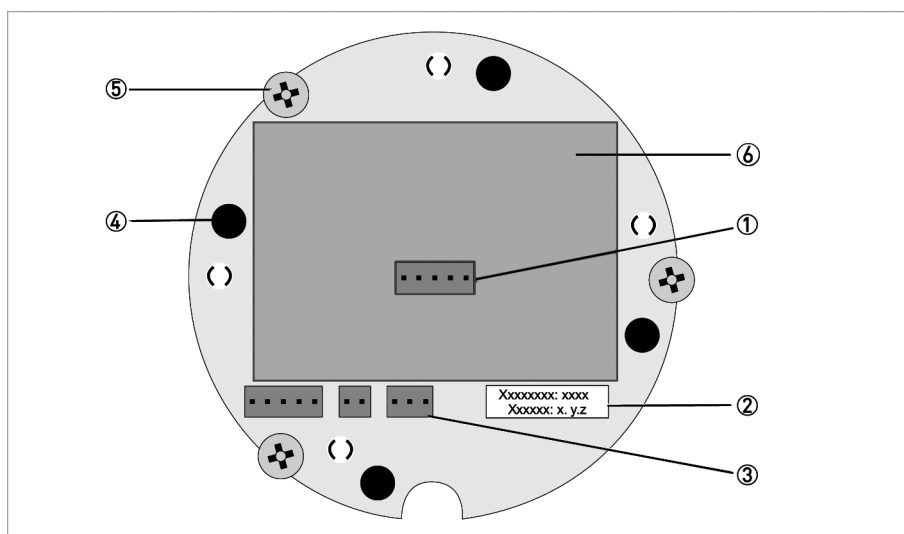

- ① Display connection
- ② Version number, software
- ③ Sensor connection
- ④ Mounting bolts, display
- ⑤ Mounting screw device insert
- ⑥ Nameplate device insert

Exchanging the entire device

Removal and installation are the responsibility of the operator.

Before disconnecting the electric connecting cable of the device, it must be ensured that all of the cables leading to the indicator part are de-energised relative to each other and to the reference potential of the hazardous area. This also applies to functional earthing conductors (FE) and equipotential bonding conductors (PA).

**CAUTION!**

- *Pressurized pipes to be depressurized before removing the flowmeter.*
- *In the case of environmentally critical or hazardous products, appropriate safety precautions must be taken with regard to residual liquids in the measuring unit.*
- *New seals must be used when re-installing the device in the piping.*



For more information

www.siemens.com/flow

Siemens A/S
Flow Instruments
Coriolisvej 1-3
DK-6400 Sønderborg

Subject to change without prior notice
Order No.: A5E02172013
Lit. No.: A5E02172013-AB
© Siemens AG 05.2015



www.siemens.com/processautomation