

Overview



MAG 8000 is a comprehensive meter which intelligent information and high performance measurement as well as the easy to install concept take cost of ownership and customer service to a new level for water meter.

Benefits

Easy to install

- Compact or remote solution with factory mounted cable and customer setting from factory
- IP68/NEMA 6P enclosure. Sensor can be buried.
- Flexible power supply - internal or external battery pack or mains power supply with battery back-up possibilities
- Superior measurement
- Down to 0.2 % maximum uncertainty
- OIML R 49 type approval
- FM Fire Service Approval
- Bi-directional measurement

Long lasting performance/Low cost of Ownership

- No moving parts means less wear and tear.
- Up to 6 to 10 years maintenance-free operation in typical revenue application
- Robust construction built for the application

Intelligent information, easy to access

- Embedded self-testing and alarm/fault detection feature
- Internal data logger
- Advanced statistics and diagnostics
- Various Add-on communication modules

Application

The following MAG 8000 versions are available as stand-alone water meters:

- MAG 8000 (7ME6810) for abstraction and distribution network
- MAG 8000 CT (7ME6820) for revenue and bulk metering

Design

MAG 8000 is designed to minimize power consumption.

The product program consists of

- Basic and advanced version
- Sensor sizes from DN 25 to 1200 (1" to 48")
- Compact and remote installation in IP68/NEMA 6P enclosure and factory-mounted cable
- SIMATIC PDM and Flow Tool PC configuration softwares

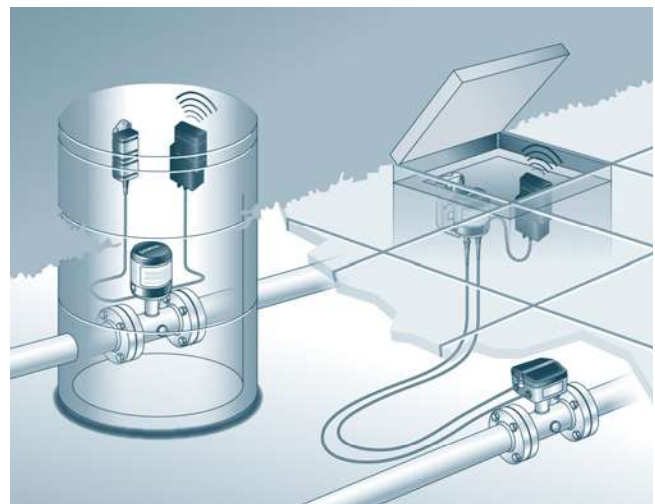

Modbus/Encoder module

Flow Measurement

SITRANS FM (electromagnetic)
Flow sensors

Battery-operated water meter MAG 8000

Function

MAG 8000 is a microprocessor-based water meter with graphical display and key for optimum customer operation and information on site. The transmitter drives the magnetic field in the sensor, evaluates the flow signal from the sensor and calculates the volume passing through. It delivers the required information via the integrated pulse output or communication interfaces as part of a system solution. Its intelligent functionality, information and diagnostic ensure optimum meter performance and information to optimize water supply and billing.



MAG 8000 can be ordered as a Basic or an Advanced version.

Features/Version	MAG 8000 Basic	MAG 8000 Advanced
Measuring frequency in battery power mode (Manually selected) ¹⁾	1/15 or 1/30 or 1/60 Hz	from 6.25 to 1/60 Hz depending of sensor size
Output MAG 8000	2 FW/RV/AI/CA	2 FW/RV/AI/CA
Communication	Add-on	Add-on
Data logger	Yes	Yes
Insulation test	Yes	Yes
Leakage detection	No	Yes
Meter utilization	No	Yes
Statistics	No	Yes
Tariff	No	Yes
Settle date (Revenue)	No	Yes

¹⁾ Excitation frequency settings with mains power supply, see technical specifications for each version:

Some information is accessible via the display whereas all information is accessible via the IrDA communication interface with the PDM software. Data and parameters are registered in a EEPROM. They can all be read, but changing the information demands a software password or a hardware key attached to the printed circuit board.

The SIMATIC PDM tool gives the possibility of testing and verifying the flowmeter on site and creating a printed "Qualification Certificate" with all specific data that define the quality status of the measurement.

The Qualification Certificate consists of two pages with information about the actual status of the sensor:

Part 1 provides general settings, sensor and battery info, totalizer values and pulse output settings.

Part 2 provides detailed information about electronic and sensor functionality and a main parameter list for evaluating the functionality of the MAG 8000 water meter.



SIMATIC PDM

For more details about SIMATIC PDF please go to chapter 8 "Digitalization and Communication".

Technical specifications

Transmitter	
Installation	Compact (integral) Remote with factory-mounted cable 5, 10, 20 or 30 m (16.4, 32.8, 65.6 or 98.4 ft)
Enclosure	Stainless steel top housing (AISI 316) and coated brass bottom. Remote wall mount bracket in stainless steel (AISI 304).
Cable entries	2 × M20 (one gland for one cable of size 6 ... 8 mm (0.02 ... 0.026 ft) is included in the standard delivery)
Display	Display with 8 digits for main information Index, menu and status symbols for dedicated information
Resolution	Totalized information can be displayed with 1, 2 or 3 decimals or automatic adjustment (default)
Flow unit	
Europe	Volume in m ³ and flow rate in m ³ /h
US	Volume in Gallon and flow rate in GPM
Australia	Volume in Mi and flow rate as MI/d
Optional display units	Volume: m ³ × 100, l × 100, G × 100, G × 1000, MG, CF × 100, CF × 1000, AF, Al, kl, BBL42 Flow: m ³ /min, m ³ /d, l/s, l/min, GPS, GPH, GPD, MGD, CFS, CFM, CFH, BBL42/s, BBL42/min, BBL42/h, BBL42/d
Digital output	2 passive outputs (MOS), individual galvanically isolated Maximum load ± 35 V DC, 50 mA short circuit protected
Output A function	Programmable as pulse volume – forward – reverse – forward/net – reverse/net
Output B function	Programmable as pulse volume (like output A), alarm
Output	Max. pulse rate of 50 Hz (pulse B) and 100 Hz (pulse A), pulse width of 5, 10, 50, 100, 500 ms

Transmitter	
Communication	IrDA: Standard integrated infrared communication interface with Modbus RTU protocol
Add-on modules	<ul style="list-style-type: none"> RS 232 serial interface with Modbus RTU (Rx/Tx/GND), point to point with max. 15 m cable RS 485 serial interface with Modbus RTU (+/-GND), multidrop with up to 32 devices with max. 1000 m cable Encoder interface module (for Itron 200WP) "Sensus protocol" 3G/UMTS module with or without analog input cable
Power supply	Auto detection of power source with display symbol for operation power
Internal battery pack	1 D-Cell 3.6 V/16.5 Ah 2 D-Cell 3.6 V/33 Ah
External battery pack	4 D-Cell 3.6 V/66 Ah
Mains power supply	12 ... 24 V AC/DC (10 ... 32 V) 2 VA 115 ... 230 V AC (85 ... 264 V) 2 VA Both mains power supply systems are upgradable for battery backup via internal D-Cell (3.6 V 16.5 Ah) or external battery pack.
Cable	3 m (9.8 ft) for external connection to mains supply (without cable plug)

Flow Measurement

SITRANS FM (electromagnetic)

Flow sensors

Battery-operated water meter MAG 8000

Technical specifications (continued)

Features	
Application identification	Tag number up to 15 characters
Time and date	Device embedded Real Time Clock (Synchronization with NTP server if 3G/UMTS module connected)
Totalizer	MAG 8000
	Totalizer 1 and Totalizer 2: Configurable to Forward, Reverse and Bidirectional netflow Totalizer 3: (following totalizer 1 setting) resetable via display key
Measurement	
Low flow cut-off	• 7ME6810 • 7ME6820
Empty pipe detection	Symbolised in display
Data logger	Logging of 26 records: selectable as daily, weekly or monthly logging
Alarm	Active alarm is indicated on the display.
Data protection	All data stored in an EEPROM. Totalizers 1 and 2 are backed up every 10 min, statistic every hour and power consumption and temperature measurement every 4 hours. Password protection of all parameters and hardware protection of calibration and revenue parameters.
Battery power management	Optimal battery information on remaining capacity. Calculated capacity includes all consuming elements and available battery capacity is adjusted related to change in ambient temperature. Numbers of power-ups Date and time registered for first and last time power alarm.
Diagnostic	
Continuous self test including	Coil current to drive the magnetic field Signal input circuit Data calculation, handling and storing
Alarm statistics and logging for fault analyzing	Electrode impedance to check actual media contact Flow simulation to check pulse and communication signal chain for correct scaling Number of sensor measurements (excitations) Transmitter temperature (battery capacity calculation) Low impedance alarm for change in media Flow alarm when defined high flow exceeds Verification mode for fast measure performance check
Insulation test	Test of signal immunity against disturbance and bad installation. Test interval is selectable and measurement is interrupted during the test period of 4 min.

Features	
Leakage detection (only Advanced version)	Monitoring the lowest flow or volume during selected time window within 24 hours. Leakage is detected over a selectable period where monitored value exceed the possible leakage level. Min. and max. values are stored with date registration. Last store value visible on the display.
Meter Utilization (only Advanced version)	6 registers for monitoring total time the meter has operated in different flow intervals. Registered intervals are free selectable as % of Q_n (Q3).
Tariff (only Advanced version)	6 tariff registers count the volume delivered within the selected tariff windows, based on time of day or flow rates or a combination. Tariff can also be used for consumption profile where consumption is related to different time intervals or flow rates. Tariff values visible on the display.
Settling date (only Advanced version)	On a predefined date the totalizer 1 index value is stored. Old values are stored to show the latest two totalized 1 index values. Settling values visible on the display.
Statistic (only Advanced version)	Min. flow rate with time and date registration Max. flow rate with time and date registration Min. daily consumption with date registration Max. daily consumption with date registration Latest 7 days total and daily consumption Actual month consumption Latest month consumption
PC Configuration Software PDM	<ul style="list-style-type: none"> • Meter configuration – online and offline mode • Own parameter settings • Parameter documentation • Print and export of data and parameters PDM 9.0/9.1 Service Pack 1

¹⁾ Siemens warrants the measurement accuracy down to a flow velocity of 15 mm/s. For a flow velocity below 15 mm/s, we don't warrant the measurement accuracy.

Technical specifications (continued)

MAG 8000 water meter uncertainty

To ensure continuous accurate measurement, flowmeters must be calibrated. The calibration is conducted at Siemens flow facilities with traceable instruments referring directly to the physical unit of measurement according to the International System of Units (SI).

Therefore, the calibration certificate ensures recognition of the test results worldwide, including the US (NIST traceability).

Siemens offers accredited calibrations assured to ISO 17025 in the flow range from 0.0001 m³/h to 10 000 m³/h. Siemens Flow Instruments accredited laboratories are recognized by ILAC MRA (International Laboratory Accreditation Corporation - Mutual Recognition Arrangement) ensuring international traceability and recognition of the test results worldwide.

The selected calibration determines the accuracy of the meter. A standard calibration results in max. $\pm 0.4\%$ uncertainty and an extended calibration $\pm 0.2\%$. A calibration certificate follows every sensor and calibration data are stored in the meter unit.

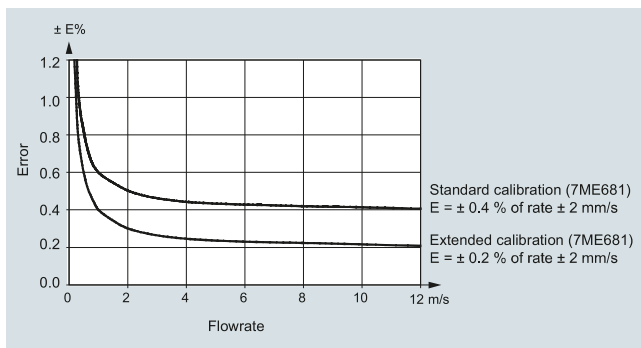

MAG 8000 (7ME6810) for Fire Service applications

MAG 8000 (7ME6810) is FM Fire Service approved for automatic fire protection systems according to the Fire Service Meters Standard, Class Number 1044. The approval is applicable for the sizes DN 50, DN 80, DN 100, DN 150, DN 200, DN 250, and DN 300 (2", 3", 4", 6", 8", 10", and 12") with ANSI B16.5 Class 150 flanges. The FM Fire Service approved product can be ordered via the Z-options P20, P21 and P22.

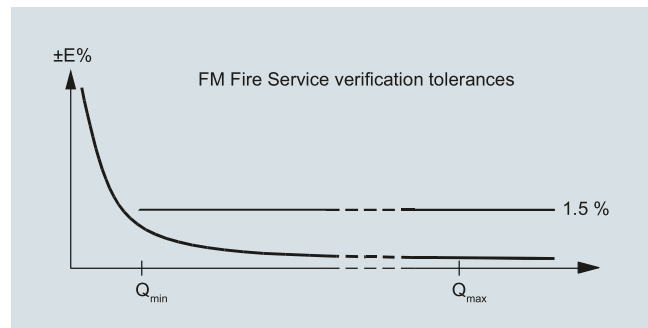

Grounding

The sensor body must be grounded using grounding straps and/or grounding rings to protect the flow signal against stray electrical noise. This ensures that the noise is carried through the sensor body and a noise-free measuring area within the sensor body. For MAG 8000 Irrigation grounding rings on both sides are factory-mounted.

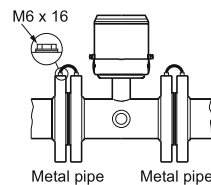

Metal pipes

On metal pipes, connect the straps to both flanges.

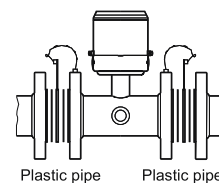

Plastic pipes

On plastic pipes and lined metal pipes, optional grounding rings must be used at both ends.

Grounding rings has to be ordered separately see "grounding ring kit"

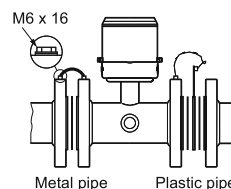

Combination of metal and plastic pipes

A combination of metal and plastic requires straps for metal pipe and grounding rings for plastic pipe.

Flow Measurement

SITRANS FM (electromagnetic)

Flow sensors

Battery-operated water meter MAG 8000

Technical specifications (continued)

Battery operation time and calculation

The battery operation time depends on the connected battery pack as well as the operation condition of the meter.

MAG 8000 calculates the remaining capacity every 4 hours and includes all consuming elements. Calculation compensates for temperature influence on battery capacity.

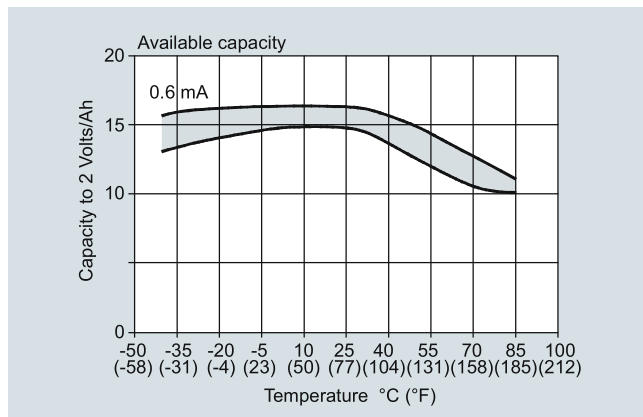

The graphic shows the effect from other temperatures. A variation in temperature from 15 °C to 55 °C (59 to 131 °F) reduces the capacity by 17 % in the table from 15 Ah to 12.5 Ah.

At typical revenue scenario of expected battery operation time can be seen in the table below.

The measurement for calculating the rest capacity of the battery life time is only completed if the system has no active fatal faults or the empty pipe is active. Maximum battery specification is 10 years operation.

Scenario - Revenue application

Output A	Pulse rate max. 10 Hz
Output B	Alarm or call-up
Meter dialog	1 hour per month
Add-com	None
Temperature profile	<ul style="list-style-type: none"> • 5 % at 0 °C (32 °F) • 80 % at 15 °C (59 °F) • 15 % at 50 °C (122 °F)

Battery lifetime (subject to the assumptions mentioned above)

MAG 8000 for abstraction and distribution network applications (7ME6810) and MAG 8000 CT for revenue and bulk metering (7ME6820)

Excitation frequency (24 h operation)		1/60 Hz	1/30 Hz	1/15 Hz	1/5 Hz	1.5625 Hz	3.125 Hz	6.25 Hz
2 D-Cell battery 33 Ah Internal battery pack	DN 25 ... 150 (1" ... 6")	9 years	9 years	7 years	43 months	8 months	3 months	2 months
	DN 200 ... 600 (8" ... 24")	9 years	6 years	4 years	22 months	3 months	1 month	N/A
	DN 700 ... 1200 (28" ... 48")	7 years	4 years	2 years	12 months	1 months	N/A	N/A
4 D-Cell battery 66 Ah External battery pack	DN 25 ... 150 (1" ... 68")	15 years	15 years	14 years	86 months	16 months	7 months	4 months
	DN 200 ... 600 (8" ... 24")	15 years	13 years	8 years	44 months	7 months	3 months	N/A
	DN 700 ... 1200 (28" ... 48")	14 years	9 years	5 years	24 months	3 months	N/A	N/A

Typical battery lifetime scenario for MAG 8000 with 3G module

Transmission once a day and MAG 8000 factory settings

2 D-Cell battery 33 Ah Internal battery pack	3 ... 4 years
4 D-Cell battery 66 Ah External battery pack	7 ... 8 years

External battery pack can be used as battery backup for mains power supply (if two cable entries in one cable gland are needed, order cable glands with two entries, see accessories on page 3/141)

Serial RS 232/RS 485 add-on communication modules are designed for mains powered systems as the battery operation time will be reduced. At 1 hour communication per month (all meter data collected 2 times per day) and the module is connected, the operation time is reduced to:

- RS 232:
 - Switched on constantly:
 - 6.4 months for 2 D-cell internal battery pack / 12.8 months for 4 D-cell ext. battery pack
 - Switched on 2 s/day:
 - 39 months for 2 D-cell internal battery pack / 78 months for 4 D-cell ext. battery pack
- RS 485:
 - With the termination resistor on:
 - 2.3 months for 2 D-cell internal battery pack / 4.6 months for 4 D-cell ext. battery pack
 - With the termination resistor off:
 - 39 months for 2 D-cell internal battery pack / 78 months for 4 D-cell ext. battery pack, in case the entire communication time is less than 4 hours/day

Dimensional drawings

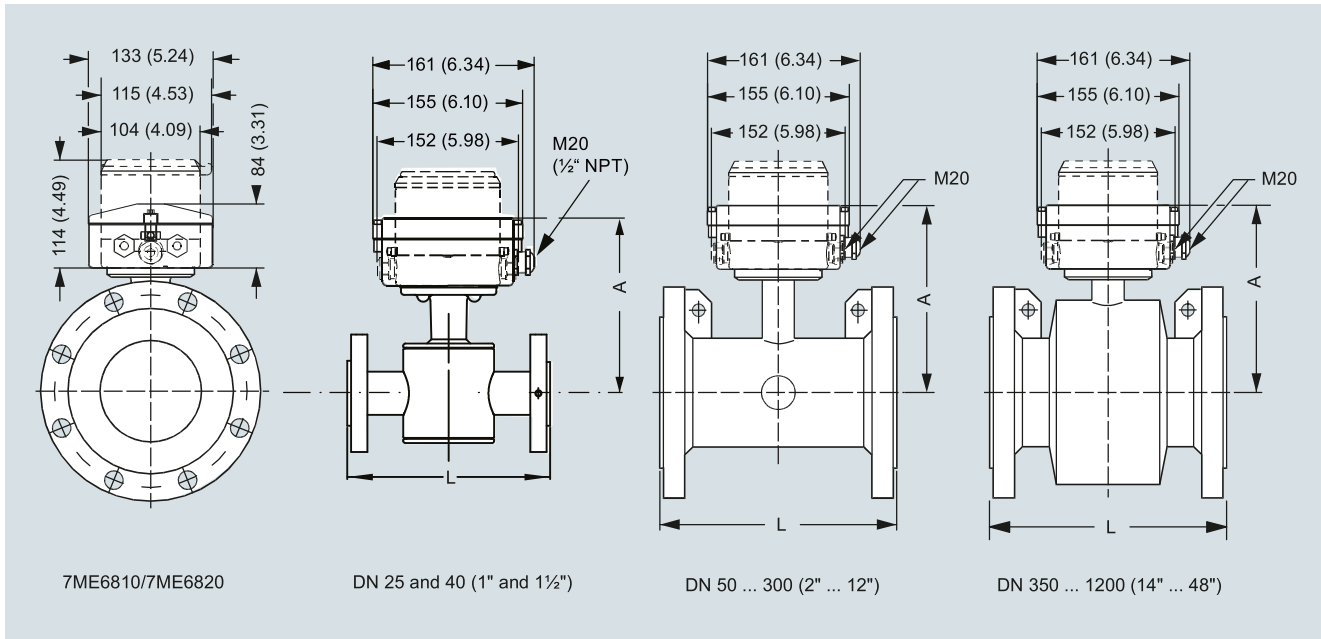

Dimensions in mm (inch)

Nominal DN size	A	L, lengths ¹⁾							Weight ²⁾	
		EPDM (7ME6810 and 7ME6820)	EN 1092-1 PN 10	EN 1092-1 PN 16/ PN 16 non-PED	EN 1092-1 PN 40	ANSI 16.5 Class 150	AS 4087 PN 16	AWA C-207 Class D	AS 2129	kg
mm (inch)	mm (inch)	mm	mm	mm	inch	mm	mm	mm		
25 (1)	188 (7.4)	-	-	200	7.9	200	-	200	6	13
40 (1½)	203 (8.0)	-	-	200	7.9	200	-	200	9	20
50 (2)	178 (7.0)	-	200	-	7.9	200	-	-	11	25
65 (2½)	181 (7.1)	-	200	-	7.9	200	-	-	13	29
80 (3)	191 (7.5)	-	200	-	7.9	200	-	-	15	34
100 (4)	197 (7.8)	-	250	-	9.8	250	-	-	17	38
125 (5)	210 (8.3)	-	250	-	9.8	250	-	250	22	50
150 (6)	224 (8.8)	-	300	-	11.8	300	-	-	28	63
200 (8)	249 (9.8)	350	350	-	13.8	350	-	-	50	113
250 (10)	276 (10.9)	450	450	-	17.7	450	-	-	71	160
300 (12)	303 (11.9)	500	500	-	19.7	500	-	-	88	198
350 (14)	365 (14.4)	550	550	-	21.7	550	-	-	127	279
400 (16)	391 (15.4)	600	600	-	23.6	600	-	-	145	318
450 (18)	421 (16.6)	600	600	-	23.6	600	-	-	175	384
500 (20)	447 (17.6)	600	600	-	23.6	600	-	-	225	494
600 (24)	497 (19.6)	600	600	-	23.6	600	-	-	340	747
700 (28)	548 (21.6)	700	875/700	-	N/A	700	700	-	316	694
750 (30)	573 (22.6)	N/A	N/A	-	N/A	N/A	750	-	N/A	N/A
800 (32)	603 (23.7)	800	1000/800	-	N/A	800	800	-	398	1045
900 (36)	656 (25.8)	900	1125/900	-	N/A	900	900	-	476	1045
1000 (40)	708 (27.9)	1000	1250/1000	-	N/A	1000	1000	-	602	1322
1050 (42)	708 (27.9)	N/A	N/A	-	N/A	N/A	1050	-	N/A	N/A
1100 (44)	759 (29.9)	N/A	N/A	-	N/A	N/A	1100	-	N/A	N/A
1200 (48)	814 (32.0)	1200	1500/1200	-	N/A	1200	1200	-	887	1996

¹⁾ Tolerances on built-in length: DN 15 to DN 200 (½" to 8"): +0/-3 mm (+0/-0.12"), DN 250 to DN 400 (10" to 16"): +0/-5 mm (+0/-0.20"), DN 450 to DN 600 (18" to 24"): +5/-5 mm (+0.20/-0.20"), DN 700 to DN 1200 (28" to 48"): +10/-10 mm (+0.39/-0.39").

²⁾ For remote version the sensor weight is reduced with 2 kg (4.5 lbs).

Flow Measurement

SITRANS FM (electromagnetic)

Flow sensors

Battery-operated water meter MAG 8000

Dimensional drawings (continued)

Remote version

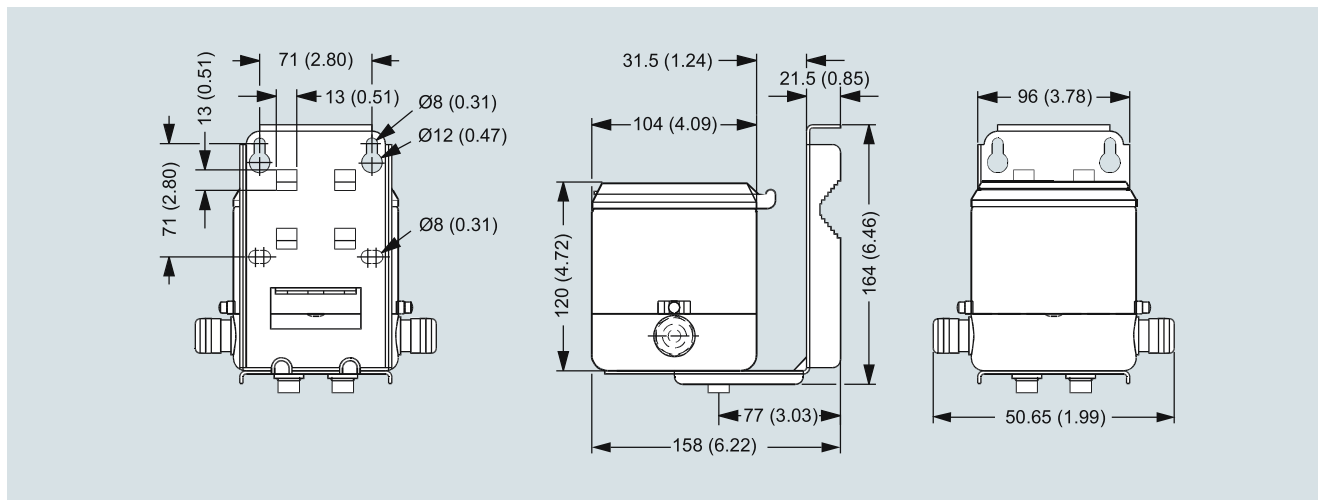

Dimensions in mm (inch), weight 3.5 kg (8 lbs)

External battery pack

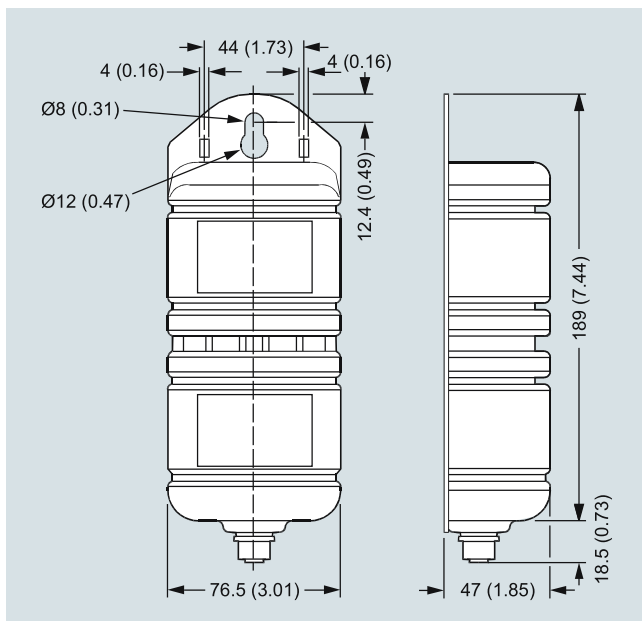

Dimensions in mm (inch), weight 2.0 kg (4.5 lbs)

Battery pack has to be mounted in upwards position to ensure maximum battery capacity.

Grounding rings

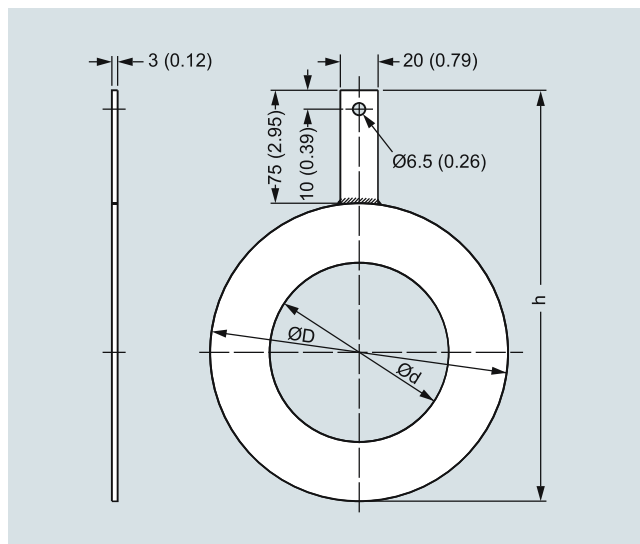

Dimensions in mm (inch) for grounding rings MAG 8000 with EPDM lining (7ME6810 and 7ME6820) DN 25 to DN 300

Dimension	Internal diameter (d)	Outside diameter (D)	h
DN 25	27	68	143
DN 40	38	88	163
DN 50	52	100	175
DN 65	64	120	195
DN 80	79	133	208
DN 100	95	158	233
DN 125	115	188	263
DN 150	145	216	291
DN 200	193	268	343
DN 250	246	324	399
DN 300	295	374	449

Circuit diagrams

Electrical installation and pulse output – Connection diagram

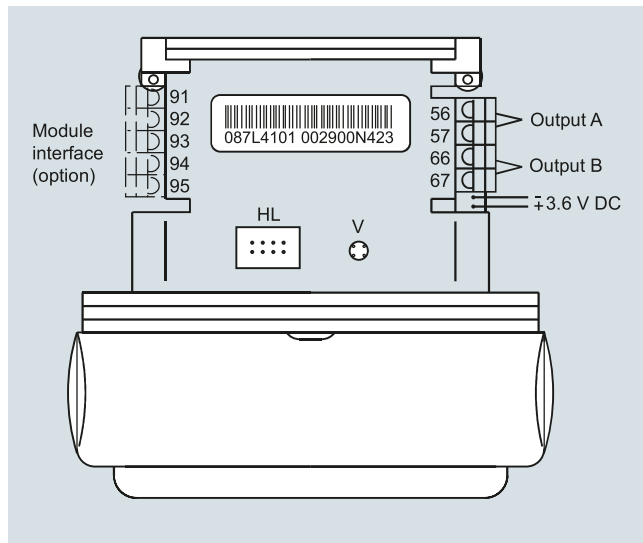

HL = Hardware lock key connection
V = Push button for verification mode

Pulse wire connection

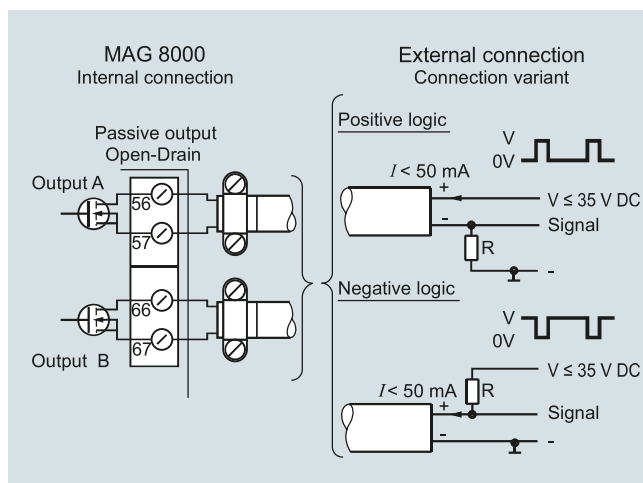

The pulse output can be configured as volume, alarm or call-up. The output can be connected as positive or negative logic. R = pull up/down is selected in relation to the V_x power supply and with a max. current I of 50 mA.

Use shielded cable to avoid EMC problems. Make sure the shield is correctly mounted under the cable clamp (no pig tail).

Flow Measurement

SITRANS FM (electromagnetic)

Flow sensors

MAG 8000 for abstraction and distribution network application (7ME6810)

Overview



3

Benefits

Easy to install

- Compact or remote solution with factory mounted cable
- IP68/NEMA 6P enclosure. Sensor can be buried.
- Flexible power supply - internal or external battery pack or mains power supply with battery back-up possibilities

Long-term stability/Low cost of ownership

- No moving parts in a robust construction means less wear and tear
- Basic and advanced transmitter versions with different optional add-on communication modules fulfil various customer requirements for high cost efficiency
- Up to 0.2 % maximum uncertainty
- Bi-directional measurement with an outstanding low flow performance
- Up to 10 years maintenance-free operation in typical applications

Intelligent information, easy to access

- Advanced information on site
- Advanced statistics and diagnostics
- Optional high-performance 3G/UMTS module offers an efficient solution for remote measurement and monitor via wireless networks.

MAG 8000 for abstraction and distribution network application (7ME6810)

Technical specifications

Meter	
Accuracy	Standard calibration: ± 0.4% ± 2 mm/s Extended calibration DN 50 ... DN 300 (2" ... 12"): ± 0.2 % of rate ± 2 mm/s
Low flow cut-off (default)	15 mm/s
Media conductivity	Clean water > 20 µs/cm
Temperature	
Ambient	-20 ... +60 °C (-4 ... +140 °F)
Media	0 ... 70 °C (32 ... 158 °F)
Storage	-40 ... +70 °C (-40 ... +158 °F)
Enclosure rating	
Remote sensor	IP68 to EN 60529/NEMA 6P, 10 mH ₂ O cont.
Compact version	IP68 to EN 60529/NEMA 6P, 3 mH ₂ O for six months
Certificates and approvals	
Calibration	
• Standard calibration	2 x 25 % and 2 x 90 % (default)
• Special calibration	5-point calibration: 20 %, 40 %, 60 %, 80 %, 100 % of factory Q _{max} 10-point calibration: ascending and descending at 20 %, 40 %, 60 %, 80 %, 100 % of factory Q _{max} Matched-pair calibration: default, 5-point, 10-point
Material certificate EN 10204-3.1	Available when ordering together with meter ¹⁾
Drinking water approvals	<ul style="list-style-type: none"> • NSF/ANSI Standard 61²⁾ (cold water) USA • WRAS (BS 6920 cold water) UK • ACS Listed France • DVGW W270 Germany • Belgaqua (B) • MCERTS (GB)
Fire Service Approvals	FM Fire Service Meter (Class Number 1044) ³⁾
Conformity	<ul style="list-style-type: none"> • PED: 2014/68/EU⁴⁾ • EMC: IEC/EN 61326
Sensor version	DN 25 ... 1200 (1" ... 48")
Sensor material	Carbon steel ASTM A 105, with corrosion resistant coating of category C4 or C5 according to ISO 12944-2
Measuring principle	Electromagnetic induction
Excitation frequency	
Basic version	
• Battery-powered	DN 25 ... 150 (1" ... 6"): 1/15 Hz DN 200 ... 600 (8" ... 24"): 1/30 Hz DN 700 ... 1200 (28" ... 48"): 1/60 Hz
• Mains-powered	DN 25 ... 150 (1" ... 6"): 6.25 Hz DN 200 ... 600 (8" ... 24"): 3.125 Hz DN 700 ... 1200 (28" ... 48"): 1.5625 Hz

Meter	
Advanced version	
• Battery-powered	DN 25 ... 150 (1" ... 6"): 1/15 Hz (adjustable up to 6.25 Hz; reduced battery lifetime) DN 200 ... 600 (8" ... 24"): 1/30 Hz (adjustable up to 3.125 Hz; reduced battery lifetime) DN 700 ... 1200 (28" ... 48"): 1/60 Hz (adjustable up to 1.5625 Hz; reduced battery lifetime)
• Mains-powered	DN 25 ... 150 (1" ... 6"): 6.25 Hz DN 200 ... 600 (8" ... 24"): 3.125 Hz DN 700 ... 1200 (28" ... 48"): 1.5625 Hz
Flanges	
EN 1092-1 (DIN 2501)	DN 25 and DN 40 (1" and 1½"); PN 40 (580 psi) DN 50 ... 150 (2" ... 6"); PN 16 (232 psi) DN 200 ... 1200 (8" ... 48"); PN 10 or PN 16 (145 psi or 232 psi) DN 350 ... DN 600 (14" ... 24"); PN25 or PN40 (362 psi or 580 psi)
ANSI 16.5 Class 150	1" ... 24": 20 bar (290 psi)
AWWA C-207	28" ... 48": PN 10 (145 psi)
AS 4087	DN 50 ... 1200 (2" ... 48"); PN 16 (232 psi)
Liner	EPDM
Electrode and grounding electrodes	Hastelloy C276/2.4819
Grounding straps	Grounding straps are premounted from the factory on each side of the sensor.

¹⁾ Has to be ordered with the meter. It is not possible to order the certificate afterwards.

²⁾ Including Annex G

³⁾ Not for sensors with 300 µm coating.

⁴⁾ For further information on PED standard and requirements see Pressure Equipment Directive in Appendix (chapter 10).

Flow Measurement

SITRANS FM (electromagnetic)
Flow sensors

MAG 8000 for abstraction and distribution network application (7ME6810)

3

Selection and ordering data

SITRANS F M MAG 8000 water meter

Article No.

7ME6810-

Click on the Article No. for the online configuration in the PIA Life Cycle Portal.

Diameter

DN 25 (1")
DN 40 (1½")
DN 50 (2")
DN 65 (2½")
DN 80 (3")
DN 100 (4")
DN 125 (5")
DN 150 (6")
DN 200 (8")
DN 250 (10")
DN 300 (12")
DN 350 (14")
DN 400 (16")
DN 450 (18")
DN 500 (20")
DN 600 (24")
DN 700 (28")¹⁾
DN 750 (30")¹⁾
DN 800 (32")¹⁾
DN 900 (36")¹⁾
DN 1000 (40")¹⁾
DN 1050 (42")¹⁾
DN 1100 (44")¹⁾
DN 1200 (48")¹⁾

2 D
2 R
2 Y
3 F
3 M
3 T
4 B
4 H
4 P
4 V
5 D
5 K
5 R
5 Y
6 F
6 P
6 Y
7 D
7 H
7 M
7 R
7 U
7 V
8 B

Flange norm and pressure rating

EN 1092-1

PN 10 (DN 200 ... 1200 (8" ... 48"))
PN 16 (DN 50 ... 1200 (2" ... 48"))
PN 16, non-PED (DN 700 ... 1200 (28" ... 48"))
PN 25 (DN 350 ... 600 (12" ... 24"))
PN 40 (DN 25 ... 50 (1" ... 1½"), DN 350 ... 600 (12" ... 24"))

B
C
D
E
F
J
L
N

ANSI B16.5

Class 150

AWWA C-207

Class D (28" ... 48")

AS 4087

PN 16 (DN 50 ... 1200 (2" ... 48"))

Sensor version

EPDM liner and Hastelloy electrodes, corrosion-resistant coating of category C4
EPDM liner and Hastelloy electrodes, 300 µm corrosion-resistant coating of category C5

3
4
1
2
3

Calibration

Standard ± 0.4 % of rate ± 2 mm/s
Extended ± 0.2 % of rate ± 2 mm/s DN 50 ... 300 (2" ... 12")
NMI M 10 (2.5%) without verification

Article No.

SITRANS F M MAG 8000 water meter

7ME6810-

Region version

Europe (m3, m3/h, 50 Hz)
USA (Gallon, GPM, 60 Hz)
Australia (ML, ML/d, 50 Hz)

1
2
3

Transmitter type and installation

Basic version integral or sensor
Basic version, remote cables mounted on sensor with IP68/NEMA 6P plugs:
• 5 m (16.4 ft)
• 10 m (32.8 ft)
• 20 m (65.6 ft)
• 30 m (98.4 ft)
Advanced version integral on sensor
Advanced version, remote cables mounted on sensor with IP68/NEMA 6P plugs:
• 5 m (16.4 ft)
• 10 m (32.8 ft)
• 20 m (65.6 ft)
• 30 m (98.4 ft)

A
B
C
D
E
K
L
M
N
P

Communication interface

No additional "add-on" communication module installed
Serial RS 485 with Modbus RTU (Terminated as end device)
Serial RS 232 with Modbus RTU
Encoder interface with Sensus protocol
3G/UMTS communication module with remote antenna; 5 m (16.4 ft) cable
3G/UMTS communication module with analog inputs and remote antenna; 5 m (16.4 ft) cable

A
B
C
D
S
T

Power supply

Internal battery (no battery included)
Internal battery pack installed¹⁾
Power cable (1.5 m (4.9 ft)) with IP68/NEMA 6P plugs for external battery (no battery included)
12/24 V AC/DC power supply with battery backup and 3 m (9.8 ft) power cable for external connection (no battery included)
115 ... 230 V AC power supply with battery backup and 3 m (9.8 ft) power cable for external connection (no battery included)

0
1
2
3
4

¹⁾ The Diameter DN 700 (28") to DN 1200 (48") is only available as remote transmitter type installation.

²⁾ Lithium batteries are subject to special transportation regulations according to United Nations "Regulation of Dangerous Goods, UN 3090 and UN 3091". Special transport documentation is required to observe these regulations. This may influence both transport time and costs.

MAG 8000 for abstraction and distribution network application (7ME6810)

Selection and ordering data	Order code	Order code
Additional information		Additional information
Please add "-Z" to Article No. and specify Order code(s) and plain text.		Please add "-Z" to Article No. and specify Order code(s) and plain text.
Certificate		Volume unit
Inspection certificate 3.1 (EN 10204) - pressure test	C01	m ³
Material certificate according to EN 10204-3.1 ¹⁾	C12	MI
Special calibration		G
5-point calibration for DN 15 ... DN 200 ²⁾	D01	AF
5-point calibration for DN 250 ... DN 600 ²⁾	D02	I x 100
5-point calibration for DN 700 ... DN 1200 ²⁾	D03	m ³ x 100
10-point calibration for DN 15 ... DN 200 ³⁾	D06	G x 100
10-point calibration for DN 250 ... DN 600 ³⁾	D07	CF x 100
10-point calibration for DN 700 ... DN 1200 ³⁾	D08	MG
Default (2 x 25 % and 2 x 90 %) match-pair calibration for DN 15 ... DN 200	D11	G x 1000
Default (2 x 25 % and 2 x 90 %) match-pair calibration for DN 250 ... DN 600	D12	CF x 1000
Default (2 x 25 % and 2 x 90 %) match-pair calibration for DN 700 ... DN 1200	D13	AI
5-point, matched-pair calibration for DN 15 ... DN 200 ²⁾	D15	kl
5-point, matched-pair calibration for DN 250 ... DN 600 ²⁾	D16	BBL42 (US oil barrel, 1 barrel = 42 US gallons)
5-point, matched-pair calibration for DN 700 ... DN 1200 ²⁾	D17	Volume unit = AF, amount per pulse A = 1 US Gallon ⁵⁾
10-point, matched-pair calibration for DN 15 ... DN 200 ³⁾	D18	Volume unit = AI, amount per pulse A = 1 US Gallon ⁵⁾
10-point, matched-pair calibration for DN 250 ... DN 600 ³⁾	D19	Volume unit = CFx100, amount per pulse A = 1 US Gallon ⁵⁾
10-point, matched-pair calibration for DN 700 ... DN 1200 ³⁾	D20	Volume unit = BBL42, amount per pulse A = 1 US Gallon ⁵⁾
Flow unit		Pulse set up
l/s	L00	(default pulse A = forward and pulse B = Alarm, pulse width = 50 ms)
MGD	L01	A function = RV, reverse flow
CFS	L02	A function = FWnet, forward net flow
l/min	L03	A function = RVnet, reverse net flow
m ³ /min	L04	A function = Off
GPM	L05	Volume per pulse A = x 0.0001 ⁴⁾
CFM	L06	Volume per pulse A = x 0.001 ⁴⁾
l/h	L07	Volume per pulse A = x 0.01 ⁴⁾
m ³ /h	L08	Volume per pulse A = x 0.1 ⁴⁾
GPH	L09	Volume per pulse A = x 1 ⁴⁾
CFH	L10	Pulse A pulse width 5 ms (volume per pulse x 1)
GPS	L11	Pulse A pulse width 10 ms (volume per pulse x 1)
MI/d	L12	Pulse A pulse width 50 ms (volume per pulse x 1)
m ³ /d	L13	Pulse A pulse width 100 ms (volume per pulse x 1)
GPD	L14	Pulse A pulse width 500 ms (volume per pulse x 1)
BBL42/s	L15	B function = FW, forward flow
BBL42/min	L16	B function = RV, reverse flow
BBL42/h	L17	B function = FWnet, forward net flow
BBL42/d	L18	B function = RVnet, reverse net flow
Totalizer		B function = Alarm
Volume calculation (default totalizer 1= forward and totalizer 2 = reverse)		B function = Call up
Totalizer 1 = RV, reverse flow	L20	Volume per pulse B = x 0.0001 ⁴⁾
Totalizer 1 = NET, net flow	L22	Volume per pulse B = x 0.001 ⁴⁾
Totalizer 2 = FW, forward flow	L30	Volume per pulse B = x 0.01 ⁴⁾
Totalizer 2 = NET, net flow	L31	Volume per pulse B = x 0.1 ⁴⁾
		Volume per pulse B = x 1 ⁴⁾

Flow Measurement

SITRANS FM (electromagnetic)

Flow sensors

MAG 8000 for abstraction and distribution network application (7ME6810)

3

Selection and ordering data	Order code
Additional information	
Please add "-Z" to Article No. and specify Order code(s) and plain text.	
Device operation	
Only operator menu activated	M11
Data logger set up (default month logging)	
DataloggerInterval = Daily	M31
DataloggerInterval = Weekly	M32
Factory mounted cables	
5 m (16.4 ft) pulse cable A+B	M81
5 m (16.4 ft) communication cable RS 232/RS 485 terminated as end device	M82
20 m (65.6 ft) pulse cable A+B	M84
20 m (65.6 ft) communication cable RS 232/RS 485 terminated as end device	M85
Cello 2 channel, input cable 3 m (9.84 ft) with Brad Harrison micro-change 3 way connector	M87
Cello 2 channel, input cable 5 m (16.4 ft) with MIL-C-26482 spec. connectors	M89
Encoder interface cable with connector for ITRON 200WP radio, length 25 ft	M90
Encoder interface cable with connector for ITRON 200WP radio, length 5 ft	M91
SOFREL cable 2 m for LS42 data logger	M92
Adaptors for conduit installation	M94
SOFREL cable 2 m for LS-Flow data logger	M97
FM Fire Service Approval	
(with ANSI B16.5 Class 150 flanges)	
DN 50, DN 80 and DN 100 (2", 3" and 4")	P20
DN 150 and DN 200 (6" and 8")	P21
DN 250 and DN 300 (10" and 12")	P22
Region/customer specific labels	
KCC label (South Korea)	W28
DIN 43863 label ¹⁾	H21
DIN 43863 label with SWM mark ¹⁾	H22
ADDC label	H23
Region specific settings	
Low flow cutoff = 5 mm/s	M20

¹⁾ Under preparation

²⁾ 20 %, 40 %, 60 %, 80 %, 100 % of factory Q_{max}

³⁾ Ascending and descending at 20 %, 40 %, 60 %, 80 %, 100 % of factory Q_{max}

⁴⁾ Pulse width = 10 ms

⁵⁾ Pulse width = 5 ms

⁶⁾ Siemens warrants the measurement accuracy down to a flow velocity of 15 mm/s. For a flow velocity below 15 mm/s, we don't warrant the measurement accuracy

Operating instructions for SITRANS F M MAG 8000

Description	Article No.
• English	A5E03071515
• German	A5E00740986

All literature is available to download for free, in a range of languages, at <http://www.siemens.com/processinstrumentation/documentation>

Operating instructions for MAG 8000 3G/UMTS communication module

Description	Article No.
• English	A5E03644134